

# Appendix

<i>The Parts of an Airplane</i> .....	110
<i>Aeronautical Glossary</i> .....	111
<i>Suggested Reading</i> .....	115
<i>NASA Resources for Educators</i> .....	118

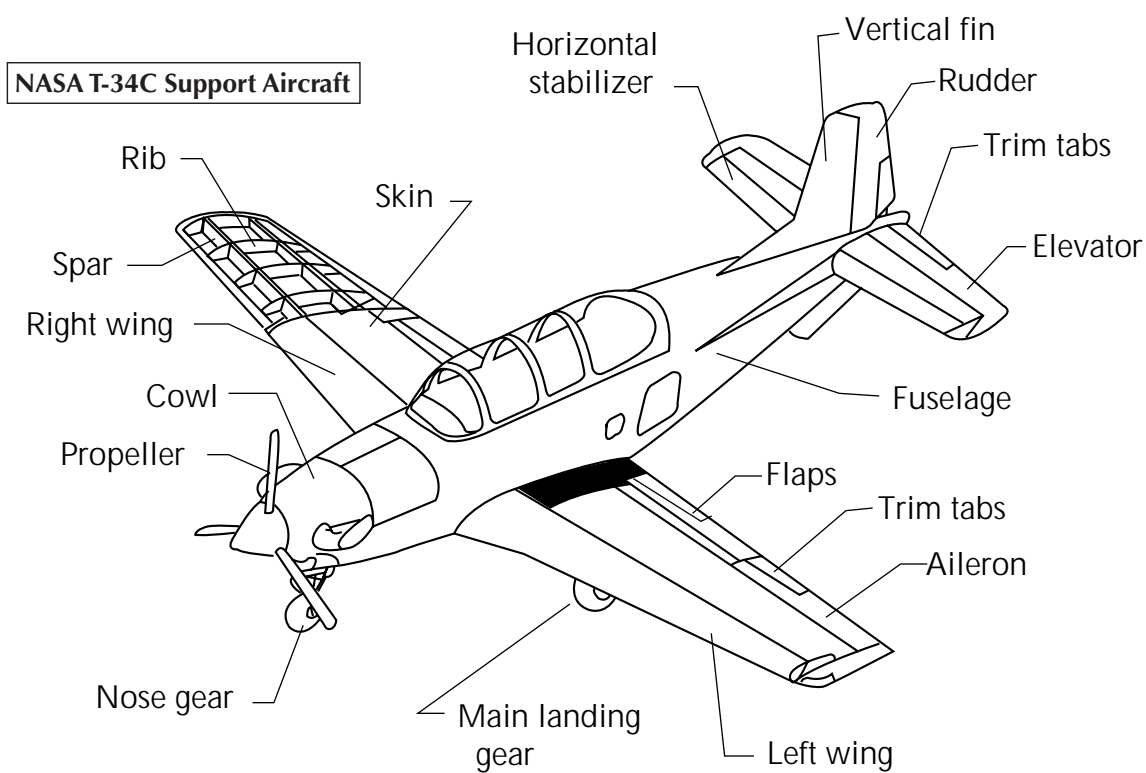



### The Parts of an Airplane

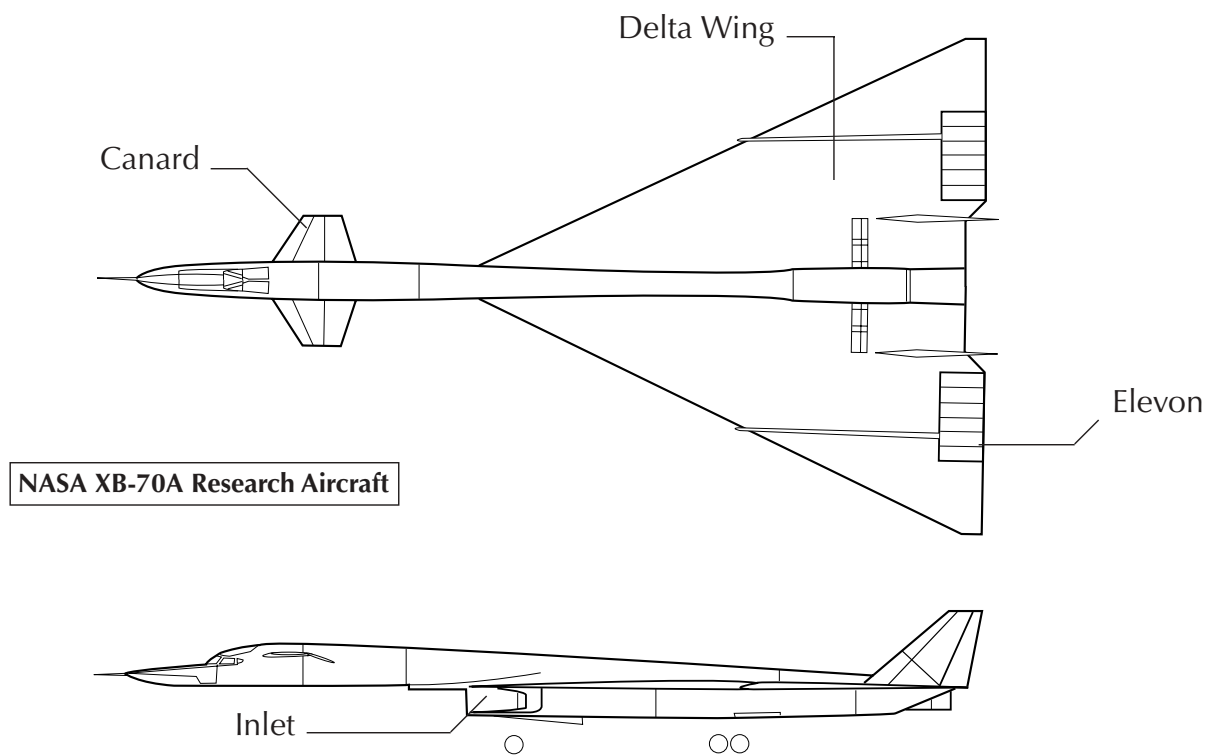

# Aeronautical Glossary

**aeronaut:** One who flies balloons.

**aeronautical chart:** A map designed for aerial navigation. Aeronautical charts include information about airports, ground elevations, landmarks, airspace designations, routes to fly, and other aids to navigation. Aeronautical charts are regularly revised to provide current information.

**airfoil:** An aerodynamic surface shaped to obtain a reaction from the air through which it moves; for example, wing, rudder, aileron or rotor blade.

**aerodynamics:** The branch of science that deals with the motion of air and the forces on bodies moving through the air.

**aileron:** Control surface, traditionally hinged to outer portion of the wing and forming part of the trailing edge, that provides control in roll as well as in banking the wings into a turn.

**angle of attack:** An engineering term that describes the angle of an aircraft's body and wings relative to its actual flight path. It is also called alpha. High angles of attack (greater than about 10 degrees) are called high alpha.

**angle of incidence:** While angle of attack varies during flight, angle of incidence is fixed with the design of the aircraft. Airfoils are generally attached to the aircraft at a small angle in relation to its longitudinal axis.

**aspect ratio:** The ratio between the length of a wing and its width (chord). Short, stubby wings (as on most jets) have a low aspect ratio; long, narrow wings (as on gliders) have a high aspect ratio.

**ATC:** Air traffic control. A system that controls air traffic from airport locations. Air traffic personnel on the ground use two-way communication with aircraft crews to maintain the safe flow of aircraft in airport vicinities, and to direct aircraft on routes between airports.

**attitude:** The orientation of the three major axes of an aircraft (longitudinal, lateral, and vertical) with respect to a fixed reference such as the horizon, the relative wind, or direction of flight. Usually refers to the relationship between the nose of the airplane and the horizon, such as the nose is pointing "above" or "below" the horizon.

**canard:** Canard has a couple of meanings. It is an aircraft with the horizontal stabilizer placed ahead of the wing instead of behind it on the tail, and it also refers to a forward horizontal stabilizer. Some aircraft have canards in addition to a conventional horizontal stabilizer on the tail.

**composite:** Usually refers to a type of structure made with layers of fiberglass or fiberglass-like materials such as carbon fiber. The materials are called composites.

**digital-fly-by-wire:** A flight control system whereby instead of mechanical links (cables and pulleys) from the cockpit to the aircraft's flight controls, wires carry electronic signals. These electric/electronic signals allow a pilot to "fly by wire." Digital refers to digital computer inputs in the system; some fly-by-wire systems use analog computers. Virtually all modern, fly-by-wire flight control systems are digital. The acronym is DFBW.

**drag:** Resistance of a vehicle body to motion through the air. A smooth surface has less drag than a rough one.

**elevator:** A movable horizontal airfoil, usually attached to the horizontal stabilizer on the tail, that is used to control pitch. It usually changes the attitude of the nose, making it move up and down.

**elevon:** Elevons are moveable control surfaces located on the trailing edge of the wings to control pitch and roll. Working in unison (both up or both down), they function as elevators. Working differentially (one up and one down), they function as ailerons.

**fin:** Another term for the vertical stabilizer (see vertical stabilizer).



**flaps:** Hinged, pivoted, or sliding airfoils or plates (or a combination of them) normally located at the trailing edge of the wing. They are designed to increase the wing's lift or otherwise improve an airplane's slow-flight characteristics.

**flight controls:** Moveable surfaces on the aircraft that control its path through the air.

**flight plan:** Specific information about the intended flight of an aircraft that is delivered orally or in writing with air traffic control.

**flight instruction:** Instruction in airplanes, and on the ground, by a person who has been certified with the Federal Aviation Administration to teach flying.

**fly-by-wire:** see digital-fly-by-wire.

**fuselage:** The main structural body of an aircraft to which the wings, tail unit, etc. are attached.

**G or g:** A symbol used to denote gravity or its effects. Also used as a unit of stress measurement for bodies undergoing acceleration, or the "loads" imposed on an aircraft and pilot. Loads may be centrifugal and aerodynamic due to maneuvering, usually expressed as g, i.e. 7 g is a load seven times the weight of the aircraft.

**glider:** An aircraft that does not use an engine for thrust. Gliders typically have relatively long, narrow wings (compared to powered aircraft) for maximum lift and minimum drag. A high lift-to-drag (glide) ratio allows the plane to fly a longer distance horizontally for every foot that it descends. High performance gliders, also known as sailplanes, can glide more than six-times the distance an average powered airplane can glide with its engine not operating.

**hangar:** A building used to house aircraft.

**helicopter:** A flying machine (heavier-than-air) that uses motor-driven rotors for support in the air. These rotors also provide the main force to propel it horizontally. A rotorcraft.

**horizontal stabilizer:** Loosely, a fixed, horizontal tail surface, but on many supersonic aircraft the entire horizontal stabilizer moves to control pitch.

**hypothesis:** A hypothesis is a proposed answer to a problem, or an explanation that accounts for a set of facts and that can be tested by further experimentation and observation. The results of experimentation provide evidence that may or may not support the hypothesis.

**inlet:** Usually, openings that let air into a jet engine.

**International Phonetic Alphabet:** A system of words identifying the letters of the alphabet and numbers. The system was reached through international agreement, and uses words chosen for their ease of pronunciation by people of all language backgrounds.

**lift:** The sum of all the aerodynamic forces acting on an aircraft at right angles to the flight path. When the aircraft is in steady level flight the lift is equal and opposite to the weight of the aircraft. Wings create lift.

**lifting body:** An aircraft that uses the shape of its body to generate lift instead of using wings.

**Mach number:** The speed of the aircraft (true air speed) divided by the speed of sound at a given temperature. Loosely, it is the speed in terms of the speed of sound, i.e. Mach 1 is the speed of sound, Mach 2 is twice the speed of sound, etc.

**meteorologist:** A weather forecaster. A person knowledgeable in the field of meteorology, which is a branch of science that deals with the physical properties of the atmosphere. Meteorology deals with the way weather conditions develop and change.

**NACA:** National Advisory Committee for Aeronautics, NASA's predecessor, 1915 to 1958.

**ornithopter:** A flying machine that is supposed to support itself in the air through the use of flapping wings.



**pitch, pitch attitude:** Loosely, the angle between the nose of an aircraft and the horizon. The nose pitches “up” or “down” in relation to level flight. It is different from angle of attack, which is the wing’s angle relative to the aircraft’s flightpath.

**ramjet:** A jet engine with no mechanical compressor, consisting of specially shaped tubes or ducts open at both ends. The air necessary for combustion is shoved into the duct and compressed by the forward motion of the engine.

**roll:** The rotation of an aircraft about its longitudinal axis. An aircraft is turned by controlling roll and yaw. A turn is initiated by “rolling” the wings into the direction of the turn. Once the turn is established, the rolling movement is stopped. A roll in the opposite direction of the turn is used to stop the turn.

**rotors:** The airfoils that are used by helicopters; they are rotated at high speeds to produce lift and thrust.

**rotor blades:** Also known as rotors.

**rotary wing aircraft:** Also known as rotorcraft. An aircraft (heavier-than-air) that uses rotating airfoils (rotary wings) to produce aerodynamic lift.

**rudder:** The primary control surface in yaw (side-ways movement), it is usually hinged and attached to the trailing edge of the vertical stabilizer on an aircraft’s tail.

**runway:** A surface on the ground specifically used for aircraft takeoffs and landings.

**shock wave:** An aircraft generates a shock wave as it flies faster than the speed of sound, pushing air molecules aside like a boat creates a bow wave. The shock wave forms a cone of pressurized air molecules which moves outward and rearward in all directions and extend to the ground.

**solar-powered aircraft:** Solar-powered aircraft, such as the Pathfinder, use photovoltaic cells to convert energy from the sun into electricity to power electric motors that drive the aircraft.

**sonic boom:** The thunder-like noise a person on the ground hears when an aircraft flies overhead faster than the speed of sound. The boom is caused by the sudden change in air pressure with the passage of a shock wave.

**stall:** A flight condition wherein the airflow separates from the airfoil surface, or the airflow around the airfoil becomes turbulent, causing the airfoil to lose lift. It is usually a result of insufficient airspeed or excessive angle of attack.

**straight-wing:** A wing that is approximately perpendicular to the fuselage.

**supersonic:** Faster than the speed of sound (about 750 mph at sea level).

**swept-wing:** A wing that has a visibly obvious, backwards or forwards inclination relative to the fuselage. The adjective swept-wing describes an aircraft that has wings which sweep forward or sweep back. Some aircraft have the ability of sweeping the wings while in flight; these wings are called variable sweep wings.

**taxi way:** An airport road (used primarily for the movement of aircraft) connecting the runway to hangars, terminals and other airport locations.

**thrust:** A force that propels an aircraft forward. Rocket and jet engine “power” is referred to in “pounds of thrust.”

**tiltrotor:** A rotor that is tilted from a horizontal alignment (as a helicopter) for takeoff and landing, to a vertical alignment (as an airplane) for level flight. Tiltrotor aircraft typically have the tiltrotors mounted on the tips of airplane-like wings, and achieve the flight characteristics of airplanes and helicopters.

**transonic:** Speeds slightly above and below the speed of sound.



**vertical stabilizer:** Sometimes referred to as a vertical fin, or fin, it is a vertical or inclined airfoil, usually at the tail or wing tip to increase directional stability. Sometimes the rudder is hinged to it.

**weight and balance:** A term referring to the distribution of weight in an aircraft and the location of its center of gravity. The center of gravity is the point where the weight is balanced. Proper weight and balance are essential for the safe operation of an aircraft.

**wind tunnel:** Tubular structures or passages, in which high-speed movements of air or other gases are produced. Objects such as engines or aircraft, airfoils, and rockets (or models of these objects) are placed inside of the wind tunnel so researchers can investigate the airflow around them and the aerodynamic forces acting upon them.

**wing loading:** Gross weight of an aircraft divided by the area of the wing. Aircraft that have proportionally large wings are said to be “wing-loaded,” while those with smaller wings, such as most jet fighters, are said to be “fuselage loaded.”

**winglet:** Small, nearly vertical, winglike surface mounted above the wing tip to reduce drag.

**wing warping:** A means to control aircraft roll by twisting (warping) the aircraft’s wing tips. The Wright brothers used wing warping on their early gliders, and on their first powered aircraft. Although wing warping was discontinued in favor of ailerons on most aircraft since 1910, the concept is still considered valid for special applications on advanced aircraft.

**yaw:** A flight condition of an aircraft in which the aircraft rotates about its vertical axis. Yawing is different from turning because an aircraft can be yawed while flying straight with the wind striking it from the side. An aircraft follows a curved flight path when turning, with the wind always flowing parallel to its longitudinal axis.

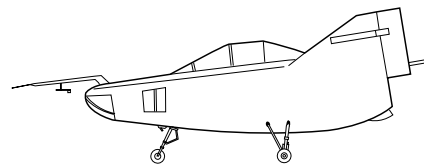

M2-F1 1963

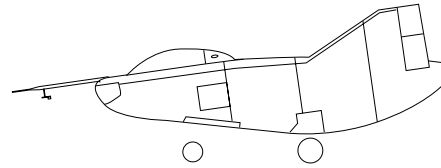

M2-F2 1966

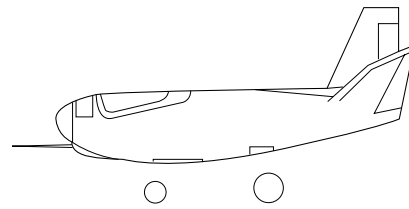

HL-10 1966

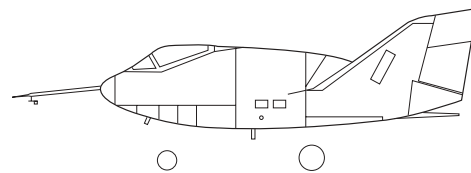

X-24A 1969

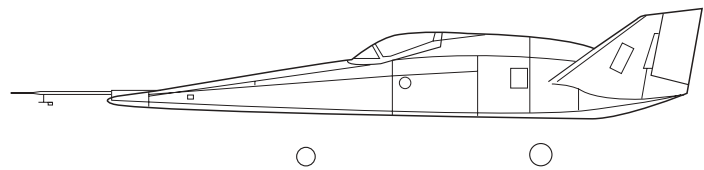

X-24B 1972

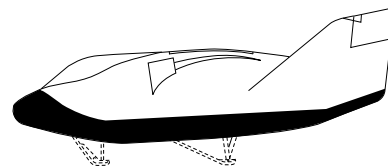

X-38 1998

## NASA Wingless Research Aircraft



## Suggested Reading

These books can be used by children and adults to learn more about aeronautics. The lists also include aviation-based fiction suitable for young readers.

### Teacher activity books:

- Aviation & Space Science Projects.* (1992). Blue Ridge Summit, PA. ISBN: 0-8306-2156-3.
- John Bringham. 1994. *Oddballs, Wing-flappers & Spinners Great Paper Airplanes.* Summit, PA: Tab Books. ISBN: 007067910X.
- E. Richard Churchill. 1990. *Fantastic Flying Paper Toys.* NY, NY: Sterling Publication, Co. ISBN: 0-8069-7460-5.
- Great American Airplanes.* (1992). Bellerophon Books. Santa Barbara, CA: Bellerophon Books. ISBN: 0-88588-113-6.
- Edward H. Mathews. 1992. *Super Endurance Paper Planes.* NY, NY: St. Martin's Press. ISBN: 0-312-08314-9.
- A. G. Smith. 1986. *History of Flight Coloring Book.* Mineola, NY: Dover Publications, Inc. ISBN: 0-486-25244-2.

### Books for students and educators:

- Jon Agee. 1994. *Return of Freddy Legrand, The.* NY, NY: Farrar, Strauss, & Giroux, Inc. ISBN: 0-374-46230-5.
- Lee J. Alnes. 1977. *Draw 50 Airplanes, Aircraft and Spacecraft.* NY, NY: Doubleday. ISBN: 0-385-23629-8.
- American Heritage History of Flight, The.* 1962. NY, NY: American Heritage Publishing Company. LCCN: 62-17517
- Mark Arceneaux. 1974. *Paper Airplanes.* Los Angeles, CA: Troubador Press. ISBN: 0-8431-1703-6.
- Isaac Asimov, Elizabeth Kaplan. 1993. *How Do Airplanes Fly?* Milwaukee, WI: Gareth Steven's, Inc. ISBN: 0-8368-0800-2.
- Renzo Barto, Judith Conaway. 1987. *Things That Go! How to Make Toy Boats, Cars, and Planes.* Mahwah, NJ: Troll Associates. ISBN: 0-8167-0839-8.
- Judith Bauer. 1990. *What's it Like to be an Airline Pilot.* Mahwah, NJ: Troll Communications. ISBN: 0-8167-1791-5.
- Cynthia Benjamin. 1997. *Working Hard With the Rescue Helicopter.* Scholastic (Tonka). ISBN 0-590-13449-2.
- Don Berliner. 1989. *World Aerobatics Championships, The.* Minneapolis, MN: Lerner Publications Company. ISBN: 0-8225-0531-2.
- Rob Bolster, Jerry Pallotta, Fred Stillwater. 1997. *Airplane Alphabet Book, The.* Watertown, MA: Charlesbridge Publishing. ISBN: 0-88106-907-8.
- Eileen Browne. 1993. *No Problem.* Cambridge, MA: Candlewick Press. ISBN: 1-56402-200-5.
- Caroline Castle, Peter Weevers. 1986. *Herbert Binns & The Flying Tricycle.* NY, NY: Dial Books for Young Readers. ISBN: 0-8037-0041-5.
- Tomie dePaola. 1975. *Cloud Book, The.* NY, NY: Holiday House. ISBN: 0-8234-0531-1.
- Frank Evans. 1994. *All Aboard Airplanes.* NY, NY: Grosset & Dunlap. ISBN-448-40214-9.
- Sarah Ferguson. 1989. *Budgie: The Little Helicopter.* NY, NY: Simon & Shuster. Books for Young Readers. ISBN: 0-671-67683-0.
- Roy Gerrard. 1992. *Jocasta Carr, Movie Star.* NY, NY: Farrar, Strauss, & Giroux. ISBN: 0-374-43777-7.
- Gail Gibbons. 1989. *Catch the Wind: All About Kites.* NY, NY: Little, Brown & Co. ISBN: 0-316-30955-9.
- David Glover. 1993. *Flying & Floating.* NY, NY: Kingfisher Books. ISBN: 1-85697-937-7.
- George W. Gray. 1948. *Frontiers of Flight, the Story of NACA Research.* Alfred A. Knopf, New York. LCCN: 48000713.
- Thomas G. Gunning. 1992. *Dream Planes.* NY, NY: Dillon Press. ISBN: 0-87518-556-8.
- Philip S. Hart. 1992. *Flying Free: America's First Black Aviators.* Minneapolis, MN: Lerner Publications, Co. ISBN: 0-8225-1598-9.
- Barbara Hayes, Phillip Mendoza. 1986. *Up, Up and Away.* NY, NY: Modern Publishing. ISBN: 0-87449-044-8.
- Mark Hewish. 1976. *Usborne Young Scientist: Jets.* London, England: Usborne Publishing Ltd. ISBN: 0-86020-051-5.
- How To Draw Wings & Wheels.* (1994). Chicago, IL: Kid's Books, Inc. ISBN: 1-56156-223-8.
- Brian S. Hurst, Olivia Newton-John. 1993. *Pig Tale, A.* NY, NY: Simon & Schuster Books for Young Readers. ISBN: 0-671-78778-0.



- Donald Jade Jackson. 1980. *The Aeronauts*. Morristown, NJ: Time-Life Books. ISBN: 0809432684.
- Terry Jennings. 1993. *Planes, Gliders, Helicopters & Other Flying Machines*. NY, NY: Kingfisher Books. ISBN: 1-85697-869-9.
- Gallimard Jeunesse. 1992. *Airplanes & Flying Machines*. USA: Cartwheel Books. ISBN: 0-590-45267-3.
- Neil Johnson. 1991. *Fire & Silk: Flying in a Hot Air Balloon*. Boston, MA: Little, Brown & Co. ISBN: 0-316-46959-9.
- Robin Kerrod. 1992. *Amazing Flying Machines*. NY, NY: Alfred A. Knopf Books for Young Readers. ISBN: 0-679-92765-4.
- Andrew Kershaw. 1992. *Super Facts Aircraft*. NY, NY: Derrydale Books. ISBN: 0-517-07324-2.
- Remi Kramer. 1994. *Legend of Lonestar Bear Book II: Soaring with Eagles, The*. Sandpoint, ID: Northwind Press. ISBN: 0-945887-14-0.
- Kate Little. 1987. *Things That Fly*. Tulsa, OK: EDC Publishing. ISBN: 0-7460-0104-5.
- Donald Lopez. 1995. *Flight*. Alexandria, VA: Time-Life Books. ISBN: 0-7835-4761-7.
- Dan Mackie. 1986. *Flight, Discover Planes, Hanggliders & Ultralights*. Burlington, Ontario, Canada: Hayes Publishing. ISBN: 0-88625-112-5.
- Doug Magee, Robert Newman. 1992. *Let's Fly From A to Z*. NY, NY: Cobblehill Books. ISBN: 0-525-65105-5.
- Jerry Mander. 1967. *Great International Paper Airplane Book, The*. NY, NY: Simon & Schuster, Inc. ISBN: 0-671-21129.
- Giovanna Mantegazza. 1994. *Look Inside an Airplane*. NY, NY: Grosset & Dunlap. ISBN: 0-448-40545-1.
- Michael Martchenko, Robert Munsch. 1988. *Angela's Airplane*. Buffalo, NY: Alnick Press. ISBN: 1-55037-026-X.
- Christopher Maynard. 1995. *Airplanes. (Mighty Machines Series.)* Dorling Kindersley. ISBN: 0-7894-0211-4.
- Christopher Maynard. 1994. *Incredible Flying Machines*. NY, NY: Covent Garden Books. ISBN: 1-56458-552-2.
- Christopher Maynard. 1993. *Little Library: Helicopters*. NY, NY: Kingfisher Books. ISBN: 1-85697-893-1.
- Nina McGuire, Sandra Wallus. 1997. *Jacqueline Cochran, America's Fearless Aviator*. Sammons. Tailored Tours Publications. ISBN: 0-9631241-6-1.
- Michael McKeevar, Georgeanne Irvine. 1991. *Day in the Life of a Test Pilot*. A. Mahwah, NJ: Troll Associates. ISBN: 0-8167-2224-2.
- Campbell Morris. 1986. *Best Paper Aircraft, The*. NY, NY: Perigee Books. ISBN: 0-399-51301-9.
- Gary Moser. 1993. *Fly: A Brief History of Flight, Illustrated*. Steven's Point, WI: Worzolla Printing. ISBN: 0-06-022893-8.
- Chris Oxlade. 1996. *Action Pack Flight*. NY, NY: D. K. Publishing, Co. ISBN: 07894-1006-0.
- Tim Paulson. 1992. *How to Fly a 747*. NY, NY: W. W. Norton. ISBN: 1-563261-061-9.
- Alice and Martin Provinsen. 1983. *Glorious Flight Across the Channel with Louis Bleriot, The*. NY, NY: Viking Press. ISBN: 0-670-34259-9.
- Edith Rumhardt. 1987. *Airplane Book*. Racine, WI: Western Publishing, Co. ISBN: 0-307-10083-9.
- Margret and H. A. Rey. 1986. *Curious George Flies a Kite*. Boston, MA: Houghton Mifflin Co. ISBN: 0-395-25937.
- Francene Sabin. 1983. *Amelia Earhart Adventure in the Sky*. Mahwah, NJ: Troll Associates. ISBN: 089575-840.
- K. Scarborough. 1993. *How it Goes: Helicopters*. Hauppauge, NY: Barron's Educational Series, Inc. ISBN: 0-8120-1993-8.
- Huck Scarry. 1991. *Big Book of Things That Go*. NY, NY: Barnes & Noble Books. ISBN: 1-56619-588-8.
- Richard Scarry. 1992. *Planes*. NY, NY: Western Publications, Co. ISBN: 0-307-11555-6.
- Mick Sellar. 1992. *Air, Wind & Flight*. NY, NY: Shooting Star Press. ISBN: 1-56924-008-6.
- Margret Rey, Alan J. Shallick. 1987. *Curious George at the Airport*. NY, NY: Scholastic, Inc. ISBN: 0-590-42186-7.
- Kaydon Stanzione. 1995. *Alyssa, Albert, & the Magic Plane*. Woodbury, NJ: Praxis-Tech. Corp. ISBN: 1-887602-10-0.
- Michael Teitelbaum. 1991. *First Facts about Flying Machines*. Chicago, IL: Kidsbooks, Inc. ISBN: 1-56156-086-3.
- Finch C. Volney, USN Retired. 1931. *Preparing for Aviation*. Simmons-Boardman Publishing Company.



A. Ward. 1981. *Usborne Pocket Scientist: Flight and Floating: Safe Experiments to do at Home*. London, England: Usborne Publishing Ltd. ISBN: 0-86020-529-0.

David Wiesner. 1992. *June 29, 1999*. Clarion Books. ISBN: 0-395-59762-5.

Mike Wimmer. 1991. *Flight*. NY, NY: Philomel Books. ISBN: 0-399-22272-3.

Martin Woodward. 1996. *Airplanes: A Foldout Book*. USA: Rand McNally. ISBN: 052885723-0.

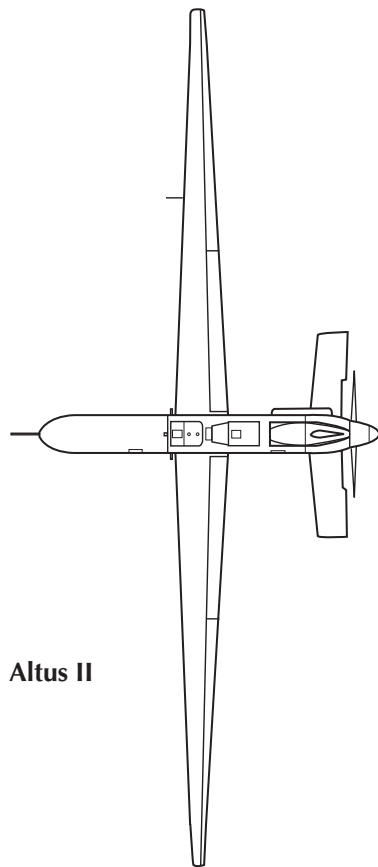

**Altus II**

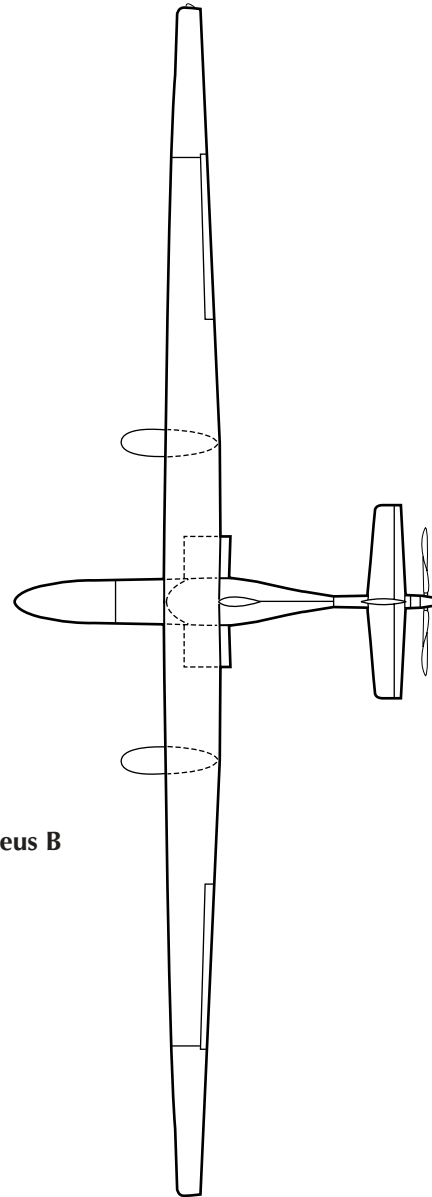

**Perseus B**

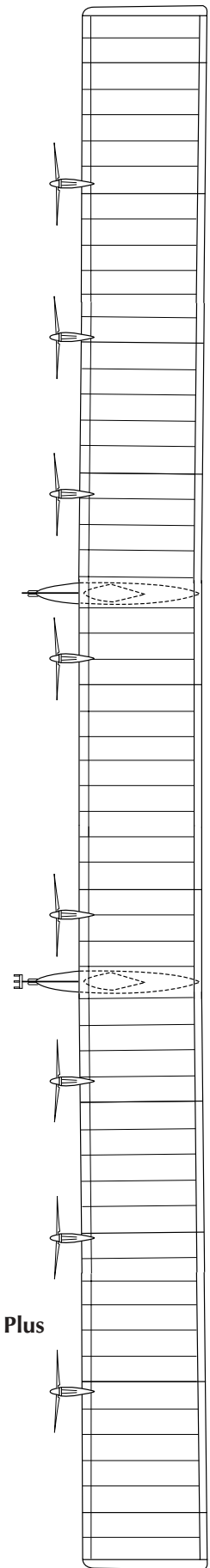

**Pathfinder Plus**

### **NASA Remotely-piloted Environmental Research Aircraft 1998**

NASA is developing several aircraft capable of flying for days at a time, at altitudes over 20,000 m, to conduct research of the earth's environment. The Altus II and Perseus B aircraft are powered by a rear-mounted piston engine and propeller. The Pathfinder Plus uses front-mounted, solar-powered electric motors and propellers. (The depicted aircraft are scaled proportionally. The Pathfinder Plus wingspan is 36.57 m.)

## NASA Resources for Educators

**NASA's Central Operation of Resources for Educators (CORE)** was established for the national and international distribution of NASA-produced educational materials in multimedia format. Educators can obtain a catalogue and an order form by one of the following methods:

NASA CORE  
Lorain County Joint Vocational School  
15181 Route 58 South  
Oberlin, OH 44074-9799  
Toll Free Ordering Line: 1-866-776-CORE  
Toll Free FAX Line: 1-866-775-1460  
E-mail [nasaco@leeca.org](mailto:nasaco@leeca.org)  
Home Page: <http://core.nasa.gov>

### **Educator Resource Center Network (ERCN)**

To make additional information available to the education community, NASA has created the NASA Educator Resource Center (ERC) network. Educators may preview, copy, or receive NASA materials at these sites. Phone calls are welcome if you are unable to visit the ERC that serves your geographic area. A list of the centers and the regions they serve includes:

*AK, Northern CA, HI, ID, MT, NV, OR, UT, WA, WY*  
NASA Educator Resource Center  
**NASA Ames Research Center**  
Mail Stop 253-2  
Moffett Field, CA 94035-1000  
Phone: (650) 604-3574

*IL, IN, MI, MN, OH, WI*  
NASA Educator Resource Center  
**NASA Glenn Research Center**  
Mail Stop 8-1  
21000 Brookpark Road  
Cleveland, OH 44135  
Phone: (216) 433-2017

*CT, DE, DC, ME, MD, MA, NH, NJ, NY, PA, RI, VT*  
NASA Educator Resource Laboratory  
**NASA Goddard Space Flight Center**  
Mail Code 130.3  
Greenbelt, MD 20771-0001  
Phone: (301) 286-8570

*CO, KS, NE, NM, ND, OK, SD, TX*  
Space Center Houston  
NASA Educator Resource Center for

**NASA Johnson Space Center**  
1601 NASA Road One  
Houston, TX 77058  
Phone: (281) 244-2129

*FL, GA, PR, VI*  
NASA Educator Resource Center  
**NASA Kennedy Space Center**  
Mail Code ERC  
Kennedy Space Center, FL 32899  
Phone: (321) 867-4090

*KY, NC, SC, VA, WV*  
Virginia Air & Space Center  
Educator Resource Center for  
**NASA Langley Research Center**  
600 Settlers Landing Road  
Hampton, VA 23669-4033  
Phone: (757) 727-0900 x 757

*AL, AR, IA, LA, MO, TN*  
U.S. Space and Rocket Center  
NASA Educator Resource Center for  
**NASA Marshall Space Flight Center**  
One Tranquility Base  
Huntsville, AL 35807  
Phone: (256) 544-5812

*MS*  
NASA Educator Resource Center  
**NASA Stennis Space Center**  
Building 1200  
Stennis Space Center, MS 39529-6000  
Phone: (228) 688-3338

*CA*  
NASA Educator Resource Center for  
**NASA Jet Propulsion Laboratory**  
Village at Indian Hill  
1460 East Holt Avenue, Suite 20  
Pomona, CA 91767  
Phone: (909) 397-4420

*AZ and Southern CA*  
NASA Educator Resource Center for  
**NASA Dryden Flight Research Center**  
PO Box 273, M/S 4839  
Edwards, CA 93523-0273  
Phone: (661) 276-5009 or (800) 521-3416 x 5009

*VA and MD's Eastern Shores*  
NASA Educator Resource Center  
**GSFC/Wallops Flight Facility**  
Visitor Center Building J-17  
Wallops Island, VA 23337  
Phone: (757) 824-2298



**Regional Educator Resource Centers** offer more educators access to NASA educational materials. NASA has formed partnerships with universities, museums, and other educational institutions to serve as regional ERCs in many states. A complete list of regional ERCs is available through CORE, or electronically via NASA Spacelink at <http://spacelink.nasa.gov/ercn>.

**NASA's Education Home Page** serves as the education portal for information regarding educational programs and services offered by NASA for the American education community. This high-level directory of information provides specific details and points of contact for all of NASA's educational efforts, Field Center offices, and points of presence within each state. Visit this resource at the following address: <http://education.nasa.gov>.

**NASA Spacelink** is one of NASA's electronic resources specifically developed for the educational community. Spacelink serves as an electronic library to NASA's educational and scientific resources, with hundreds of subject areas arranged in a manner familiar to educators. Using Spacelink Search, educators and students can easily find information among NASA's thousands of Internet resources. Special events, missions, and intriguing NASA Web sites are featured in Spacelink's "Hot Topics" and "Cool Picks" areas. Spacelink may be accessed at: <http://spacelink.nasa.gov>.

NASA Spacelink is the official home to electronic versions of NASA's Educational Products. A complete listing of NASA Educational Products can be found at the following address: <http://spacelink.nasa.gov/products>.

**NASA Television (NTV)** features Space Station and Shuttle mission coverage, live special events, interactive educational live shows, electronic field trips, aviation and space news, and historical NASA footage. Programming has a 3-hour block—Video (News) File, NASA Gallery, and Education File—beginning at noon Eastern and repeated four more times throughout the day. Live feeds preempt regularly scheduled programming.

Check the Internet for programs listings at: <http://www.nasa.gov/ntv>

For more information on NTV, contact:  
NASA TV  
NASA Headquarters - Code P-2  
Washington, DC 20546-0001  
Phone (202) 358-3572

### NTV Weekday Programming Schedules (Eastern Times)

Video File	NASA Gallery	Education File
12-1 p.m.	1-2 p.m.	2-3 p.m.
3-4 p.m.	4-5 p.m.	5-6 p.m.
6-7 p.m.	7-8 p.m.	8-9 p.m.
9-10 p.m.	10-11 p.m.	11-12 p.m.
12-1 a.m.	1-2 a.m.	2-3 a.m.

### How to Access Information on NASA's Education Program, Materials, and Services (EP-2000-09-345-HQ)

This brochure serves as a guide to accessing a variety of NASA materials and services for educators. Copies are available through the ERC network, or electronically via NASA Spacelink.

Please take a moment to evaluate this product at [http://ehb2.gsfc.nasa.gov/edcats/educator\\_guide](http://ehb2.gsfc.nasa.gov/edcats/educator_guide). Your evaluation and suggestions are vital to continually improving NASA educational materials. Thank You.

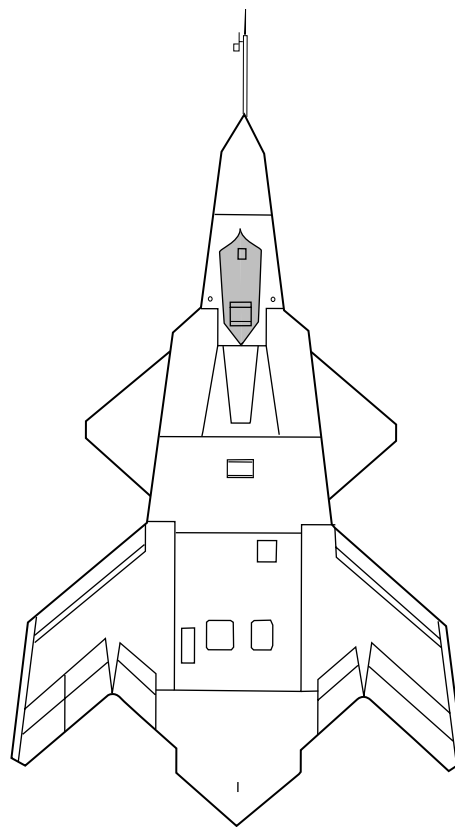

**NASA X-36 Research Aircraft  
1997**

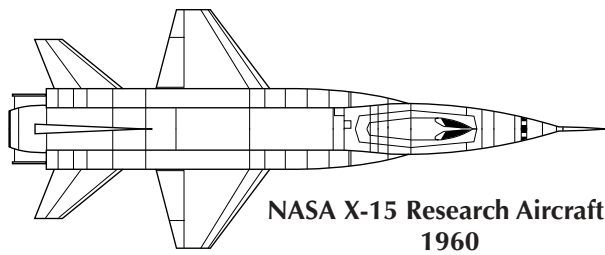

The following listing of Internet addresses will provide users with links to educational materials throughout the World Wide Web (WWW) related to aeronautics and aviation.

### **NASA Aeronautics Centers**

#### **Education Home Pages:**

NASA Ames Research Center

<http://education.arc.nasa.gov>

NASA Dryden Flight Research Center

<http://trc.dfrc.nasa.gov>

NASA Langley Research Center

<http://edu.larc.nasa.gov>

NASA Lewis Research Center

<http://www.lerc.nasa.gov/Doc/educatn.htm>

### **NASA Aeronautics Photographs and Images**

Dryden Flight Research Center Photo Gallery. Hundreds of photographs from the 1940's to the present depicting NACA and NASA flight research.

<http://www.dfrc.nasa.gov/gallery/photo/>

NASA Image eXchange (NIX).

A web-based tool for simultaneously searching several NASA image archives on the Internet. NIX searches databases of over 300,000 on-line NASA images.

<http://nix.nasa.gov/>

NASA Multimedia Gallery.

A collection of links to most of NASA on-line video, audio, and photo imagery.

<http://www.nasa.gov/gallery/index.html>

NASA Photo Gallery.

A collection of links to most of NASA still photo imagery available on-line.

<http://www.nasa.gov/gallery/photo/index.html>

### **Other Aeronautics Education Websites**

The National Coalition for Aviation Education.

Provides a list of over thirty member organizations and contacts, including: the Air Line Pilots Association, 4-H Aerospace Educations Programs, the Soaring Society of America, and Women in Aviation, International.

<http://www.aviationeducation.org/>

The K-8 Aeronautics Internet Textbook (K8AIT).

Provides on-line lesson plans, student activities covering subjects that include the principles of aeronautics, and aerodynamics in sports technology. An aeronautics career guide, and tour of NASA projects relevant to K8AIT is also offered.

<http://wings.avkids.com/>

The Aeronautics Sign Language Dictionary.

Provides 3-D animated aviators demonstrating aeronautical terms in sign language.

<http://wings.avkids.com/Book/Signing/>

The U.S. Centennial of Flight Commission provides a wide range of suggestions for how educators can engage their students in celebrating the 100th anniversary of powered flight.

<http://www.centennialofflight.gov/education.htm>

Reliving the Wright Way is a rich resource of information on the Wright Brothers and their process of invention. Designed for use by educators and students, the Web site offers everything from online, interactive demonstrations of how the Wright Flyer worked to a regularly updated calendar of events related to the celebration of the Centennial of Flight.

<http://wright.nasa.gov>



National Air and Space Museum (NASM) - Smithsonian Institution.

The NASM was established to memorialize the development of aviation and space flight, and provide educational materials for the study of aviation.

<http://www.nasm.si.edu/>

United States Air Force Museum Home Page.

The United States Air Force Museum near Dayton, Ohio is the oldest and largest military aviation museum in the world.

<http://www.wpafb.af.mil/museum/>

Planes of Fame Museum.

In addition to information about its collection, this aviation museum in Chino, California is an excellent source of aviation links on-line.

<http://www.planesoffame.org/links.htm>

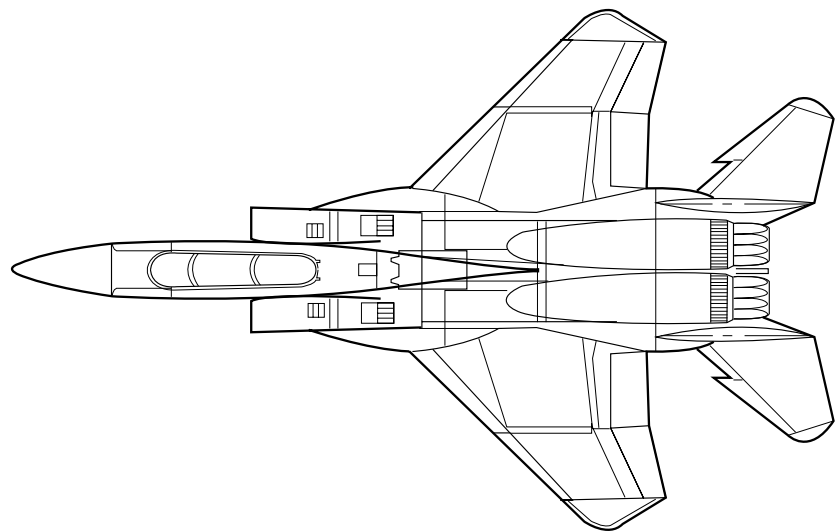

**NASA F-15B Aerodynamic Flight Facility (AFF)  
1999**

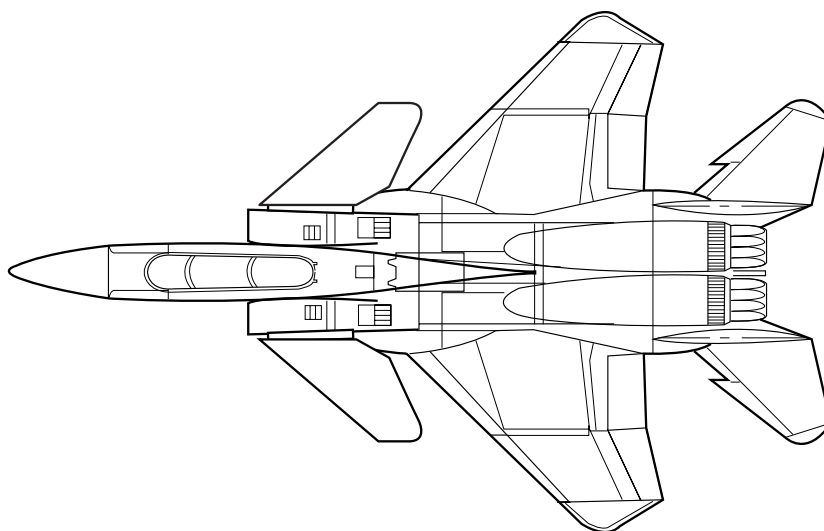

**NASA F-15B Advanced Control Technology for  
Integrated Vehicles (ACTIVE)  
1999**

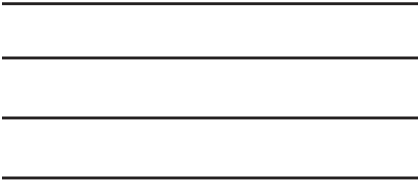

Please Place  
Stamp Here  
Post Office  
Will Not Deliver  
Without Proper  
Postage

**NATIONAL AERONAUTICS AND SPACE ADMINISTRATION  
EDUCATION DIVISION  
MAIL CODE FE  
WASHINGTON DC 20546-0001**



---

Fold along line and tape closed.

# Aeronautics—An Educator's Guide with Activities in Science, Mathematics, and Technology Education

## EDUCATOR REPLY CARD

To achieve America's goals in Educational Excellence, it is NASA's mission to develop supplementary instructional materials and curricula in science, mathematics, geography, and technology. NASA seeks to involve the educational community in the development and improvement of these materials. Your evaluation and suggestions are vital to continually improving NASA educational materials.

Please take a moment to respond to the statements and questions below. You can submit your response through the Internet or by mail. Send your reply to the following Internet address:  
  
[http://ehb2.gsfc.nasa.gov/edcats/educator\\_guide](http://ehb2.gsfc.nasa.gov/edcats/educator_guide)  
  
 You will then be asked to enter your data at the appropriate prompt.

Otherwise, please return the reply card by mail. Thank you.

- With what grades did you use the educator's guide?  
 Number of Teachers/Faculty: \_\_\_\_\_  
 \_\_\_\_\_ K-4 \_\_\_\_\_ 5-8 \_\_\_\_\_ 9-12 \_\_\_\_\_ Community College  
 College/University - \_\_\_\_\_ Undergraduate \_\_\_\_\_ Graduate  
  
 Number of Students:  
 \_\_\_\_\_ K-4 \_\_\_\_\_ 5-8 \_\_\_\_\_ 9-12 \_\_\_\_\_ Community College  
 College/University - \_\_\_\_\_ Undergraduate \_\_\_\_\_ Graduate  
  
 Number of Others:  
 \_\_\_\_\_ Administrators/Staff \_\_\_\_\_ Parents \_\_\_\_\_ Professional Groups  
 \_\_\_\_\_ General Public \_\_\_\_\_ Civic Groups \_\_\_\_\_ Other
- What is your home 5- or 9-digit zip code? \_\_\_\_\_
- This is a valuable educator's guide?  
 Strongly Agree  Agree  Neutral  Disagree  Strongly Disagree
- I expect to apply what I learned in this educator's guide.  
 Strongly Agree  Agree  Neutral  Disagree  Strongly Disagree

Fold along line and tape closed.

- What kind of recommendation would you make to someone who asks about this educator's guide?  
 Excellent  Good  Average  Poor  Very Poor
- How did you use this educator's guide?  
 Background Information  Critical Thinking Tasks  
 Demonstrate NASA Materials  Demonstration  
 Group Discussions  Hands-On Activities  
 Integration Into Existing Curricula  Interdisciplinary Activity  
 Lecture  Science and Mathematics  
 Team Activities  Standards Integration  
 Other: Please specify: \_\_\_\_\_
- Where did you learn about this educator's guide?  
 NASA Educator Resource Center  
 NASA Central Operation of Resources for Educators (CORE)  
 Institution/School System  
 Fellow Educator  
 Workshop/Conference  
 Other: Please specify: \_\_\_\_\_
- What features of this educator's guide did you find particularly helpful?  
 \_\_\_\_\_  
 \_\_\_\_\_
- How can we make this educator's guide more effective for you?  
 \_\_\_\_\_  
 \_\_\_\_\_
- Additional comments:  
 \_\_\_\_\_  
 \_\_\_\_\_

Today's Date: \_\_\_\_\_ **EG-2002-06-105-HQ**